

# MORGAN PRODUCTS

PNEUMATIC CHEMICAL PUMPS FOR THE GAS AND OIL INDUSTRIES

## MODEL 425DS-TR2-SR1S / 435DS-TR2-SR1S

AIR ACTUATED POSITIVE DISPLACEMENT PUMP

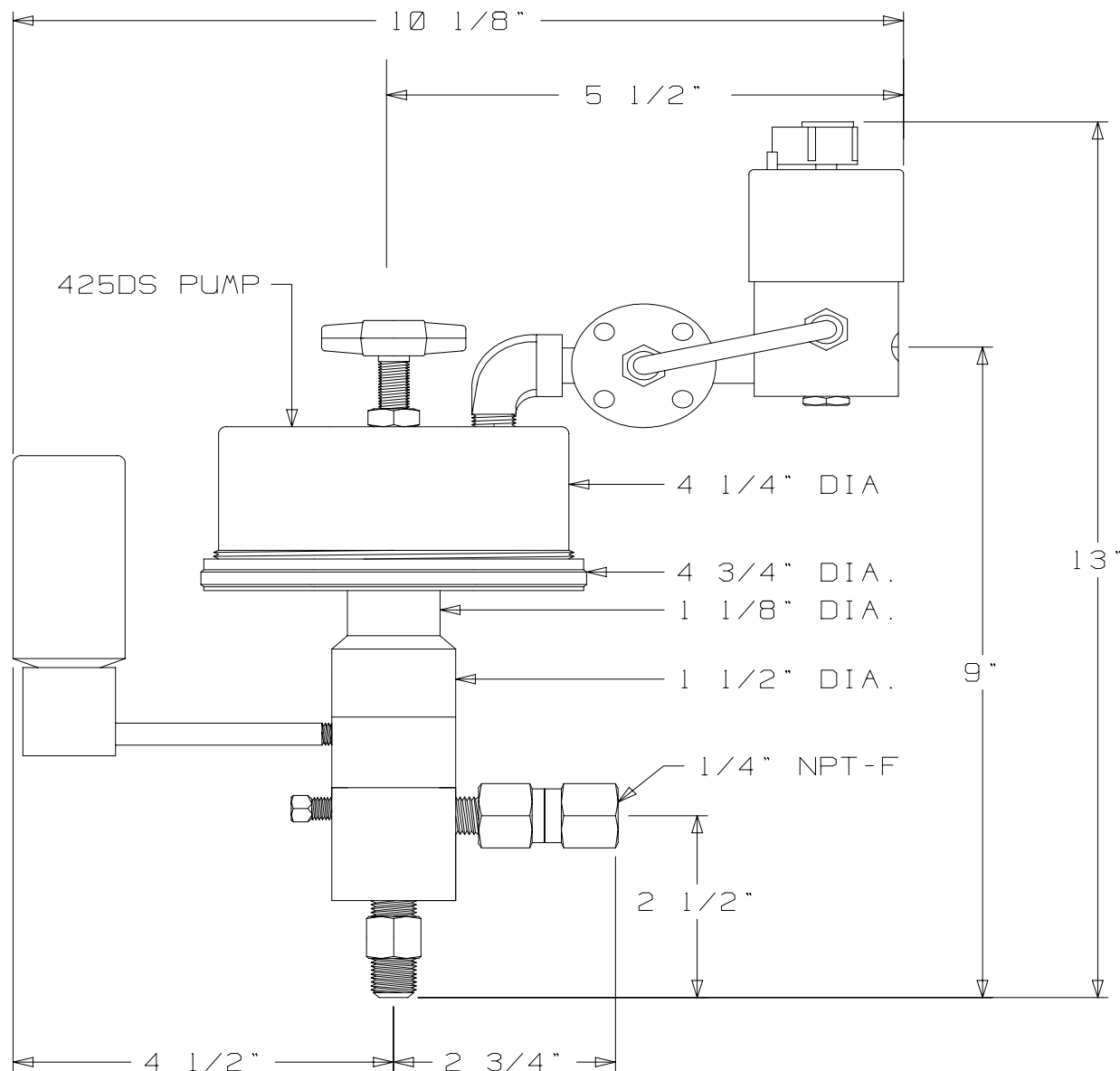

MODEL (WITH TIMER)	DISPLACEMENT	PUMP RATIO	STROKE LENGTH in. - cm.	CONNECTIONS ALL NPT INPUT / OUTPUT	MAXIMUM DISCHARGE PSI - BAR	OUTPUT PER HOUR GAL. / LTS.
425DS-TR2-SR1S	.8 cc	217:1	1 - 2.54	1/4 - M / 1/4 - F	15000 - 1034	.06 - .63 / .24 - 2.4
435DS-TR2-SR1S	1.8 cc	97:1	1 - 2.54	1/4 - M / 1/4 - F	10000 - 689	.15 - 1.5 / .55 - 5.5

**MORGAN PRODUCTS INC.** 28103 Ave. Stanford / Valencia, CA 91355

(805) 257-3022 - (800) 421-8910 - FAX (805) 257-3385

www.morganproducts.com - E-Mail info@morganproducts.com

# MORGAN PRODUCTS

## PNEUMATIC CHEMICAL PUMPS FOR THE GAS AND OIL INDUSTRIES Parts List Model 225DS, 325DS, 425DS

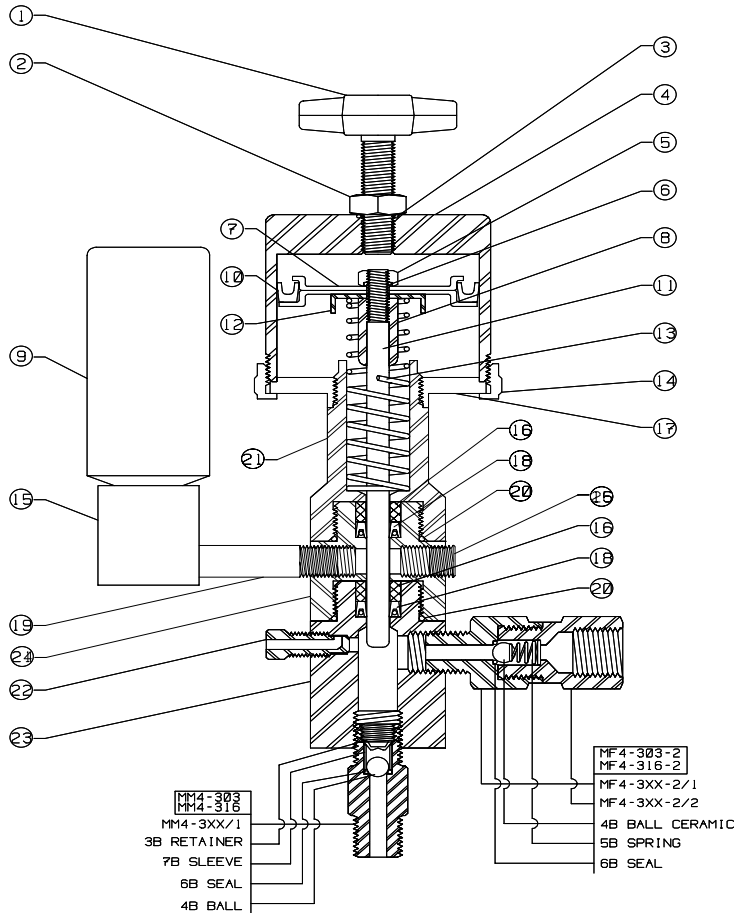

NO	NAME	PART NO.	PUMP MODEL
1	Stroke Adjuster	100-1	ALL
2	Locknut	100-2	ALL
3	O-Ring Seal	100-3 *	ALL
4	Air Chambers	200-4	200DS/225DS
		300-4	300DS/325DS
		400-4	400DS/425DS
5	Piston Locknut	100-7	ALL
6	O-Ring Seal	100-11 *	ALL
7	Pistons	200-8	200DS/225DS
		300-8	300DS/325DS
		400-8	400DS/425DS
8	Spring Guide	200-10	ALL
9	2oz. Oil	100-24	ALL
10	Piston Seals	200-9 *	200DS/225DS
		300-9 *	300DS/325DS
		400-9 *	400DS/425DS
11	Plungers:		
	17-4 TN	100-65 *	ALL
	316 SS	125-67	Optional
	Carpenter 20	100-68	Optional
12	Piston Stop	200-69	ALL
13	Return Spring	200-13 *	ALL
14	Air Chamber Rings	200-5	200DS/225DS
		300-5	300DS/325DS
		400-5	400DS/425DS
15	Reservoir	3000-25	ALL
16	Back Up Ring	100-19 *	ALL (2)
17	Faceplates	200-6	200DS/225DS
		300-6	300DS/325DS
		400-6	400DS/425DS
18	Pressure Seals:		
	TG	100-20 *	ALL (2)
	Buna- N	100-20B	Optional
	Viton	100-20V	Optional
	Fluoraz	100-20F	Optional
19	Nipples	100DS-32	200DS/225DS
		3000-32	300DS/325DS
		4000-32	400DS/425DS
20	O-Ring Seal	100-21 *	ALL (2)
21	Oil Chamber	200-14	ALL
22	Bleeder Plugs	125-22	ALL
23	Fluid Chambers	125-23	ALL
24	Double Seal Body	125-64	ALL
25	1/8 NPT Plug	5000-38	ALL
	1oz. Grease	*	ALL
	Elbow	400-27	400DS/425DS
	Lock Screw	400-28 (2)	400DS/425DS
	1/4" Washer	400-29 (2)	400DS/425DS
	Repair Kits:		
	17-4 TN Plunger	200-70	200DS/225DS
		300-70	300DS/325DS
		400-70	400DS/425DS
	316 SS Plunger	225-70	200DS/225DS
		325-70	300DS/325DS
		425-70	400DS/425DS
	Seal Sets:		
	TG	100-48	ALL
	Buna- N	100-48B	ALL
	Viton	100-48V	ALL
	Fluoraz	100-48F	ALL

\* = Included in Repair Kit

### INSTALLATION INSTRUCTIONS

1. Discard all red plastic closures.
2. Connect suction check valve, to a gravity fed chemical source.
3. Connect discharge check valve, to process line.
4. Connect a regulated air or gas supply, to the timing relay.
5. Fill oil reservoir with oil provided.  
\*\* This must be done BEFORE start up.\*\*
6. Open bleeder valve until chemical flows from bleeder.
7. Set regulator at 10 to 15 psi ABOVE the pressure required.  
(See discharge pressure graph).
8. Set cycle rate in strokes per minute.  
(See volume graph)

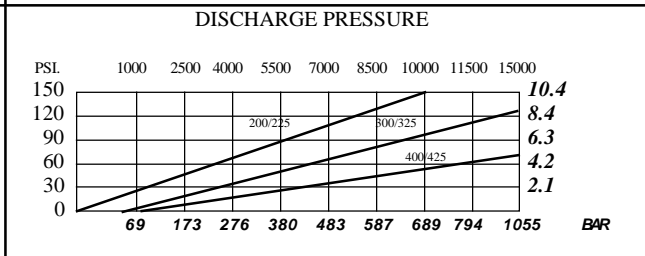
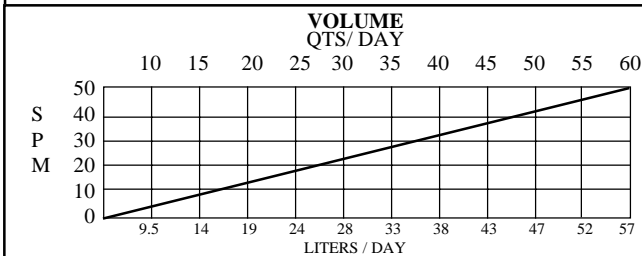

MORGAN PRODUCTS INC. 28103 Ave. Stanford / Valencia, CA 91355

(805) 257-3022 - (800) 421-8910 - FAX (805) 257-3385

# MORGAN PRODUCTS

PNEUMATIC CHEMICAL PUMPS FOR THE GAS AND OIL INDUSTRIES

## Parts List Model 235DS, 335DS, 435DS

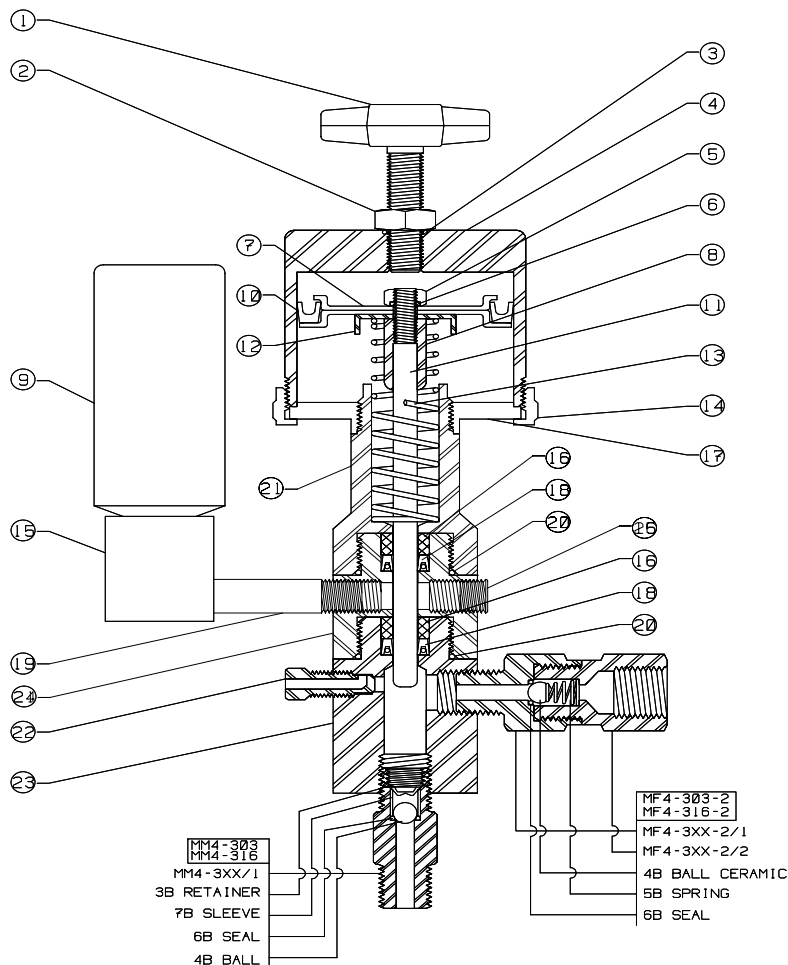

### INSTALLATION INSTRUCTIONS

1. Discard all red plastic closures.
2. Connect suction check valve, to a gravity fed chemical source.
3. Connect discharge check valve, to process line.
4. Connect a regulated air or gas supply, to the timing relay.
5. Fill oil reservoir with oil provided.  
\*\* This must be done BEFORE start up.\*\*
6. Open bleeder valve until chemical flows from bleeder.  
(See discharge pressure graph).
7. Set regulator at 10 to 15 psi ABOVE the pressure required.  
(See discharge pressure graph).
8. Set cycle rate in strokes per minute.  
(See volume graph)

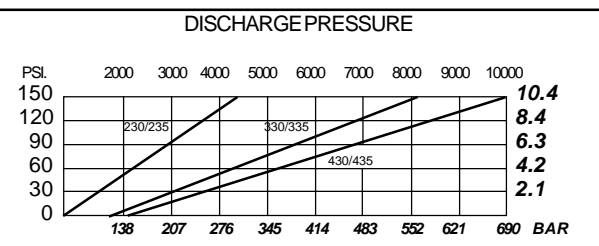
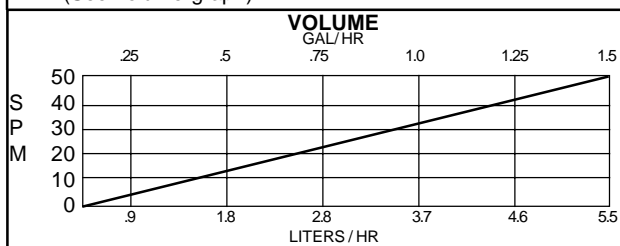

NO	NAME	PART NO.	PUMP MODEL
1	Stroke Adjuster	100-1	ALL
2	Locknut	100-2	ALL
3	O-Ring Seal	100-3	* ALL
4	Air Chambers	200-4 300-4 400-4	230DS/235DS 330DS/335DS 430DS/435DS
5	Piston Locknut	100-7	ALL
6	O-Ring Seal	100-11	* ALL
7	Pistons	200-8 300-8 400-8	230DS/235DS 330DS/335DS 430DS/435DS
8	2oz. Oil	100-24	ALL
9	Piston Seals	200-9 300-9 400-9	* 230DS/235DS * 330DS/335DS * 430DS/435DS
10	Plungers:		
	17-4 TN	230-65	* ALL
	316 SS	235-67	Optional
	Carpenter 20	230-68	Optional
11	Piston Stop	200-69	ALL
12	Return Spring	200-13	* ALL
13	Air Chamber Rings	200-5 300-5 400-5	230DS/235DS 330DS/335DS 430DS/435DS
14	Reservoir	3000-25	ALL
15	Back Up Ring	230-19	*+ ALL (2)
16	Faceplates	200-6 300-6 400-6	230DS/235DS 330DS/335DS 430DS/435DS
17	Pressure Seals:		
	TG	230-20	*+ ALL (2)
	Buna-N	230-20B	Optional
	Viton	230-20V	Optional
	Fluoraz	130-20F	Optional
18	Nipples	100DS-32 3000-32 4000-32	230DS/235DS 330DS/335DS 430DS/435DS
19	O-Ring Seal	100-21	* ALL (2)
20	Oil Chamber	230-14	ALL
21	Bleeder Plugs	125-22	ALL
22	Fluid Chambers	235-23	ALL
23	Double Seal Body	235-64	ALL
24	1/8 NPT Plug	5000-38	ALL
	1oz. Grease	*	ALL
	Elbow	400-27	430DS/435DS
	Lock Screw	400-28	(2) 430DS/435DS
	1/4" Washer	400-29	(2) 430DS/435DS
	Repair Kits:		
	17-4 TN Plunger	230-70 330-70 430-70	230DS/235DS 330DS/335DS 430DS/435DS
	316 SS Plunger	235-70 335-70 435-70	230DS/235DS 330DS/335DS 430DS/435DS
	Seal Sets:		
	TG	230-48	ALL
	Buna-N	230-48B	ALL
	Viton	230-48V	ALL
	Fluoraz	230-48F	ALL

\* = Included in Repair Kit  
+ = Included in Seal Set

MORGAN PRODUCTS INC. 28103 Ave. Stanford / Valencia, CA 91355

(805) 257-3022 - (800) 421-8910 - FAX (805) 257-3385

Web [www.morganproducts.com](http://www.morganproducts.com) - E-Mail [info@morganproducts.com](mailto:info@morganproducts.com)