

# MORGAN PRODUCTS

PNEUMATIC CHEMICAL PUMPS FOR THE GAS AND OIL INDUSTRIES

## MODEL D10-PVC-TR2

AIR ACTUATED POSITIVE DISPLACEMENT PUMP

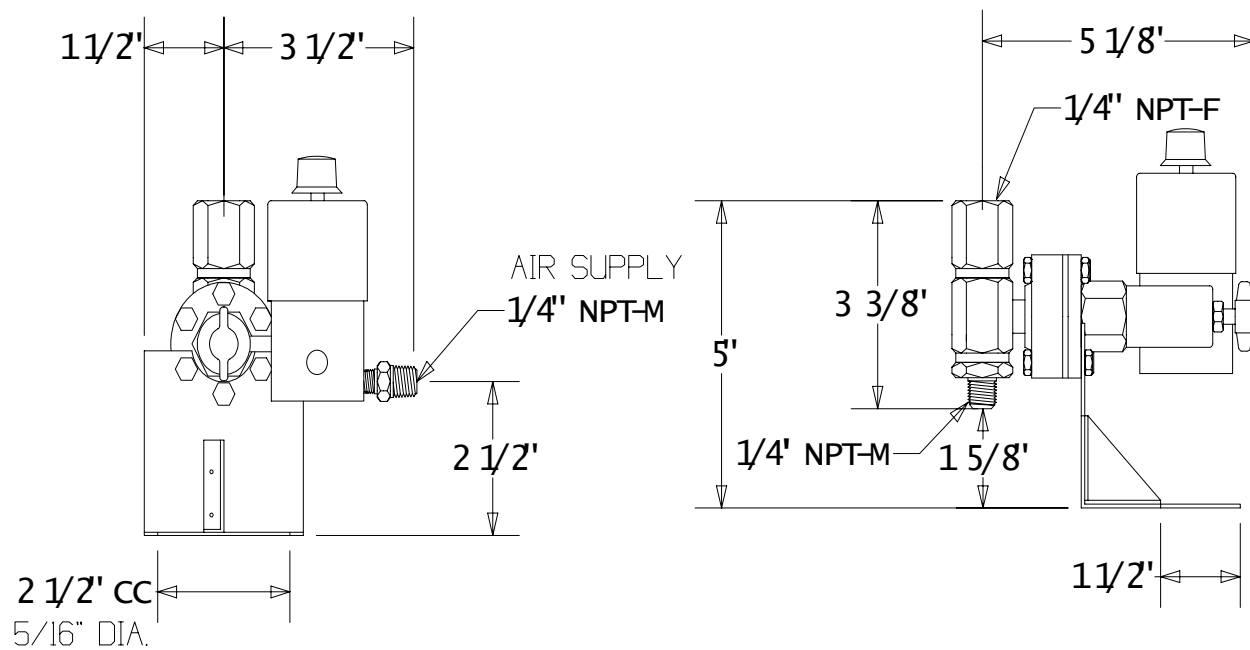

Note:

Mounting Bracket may be removed

MODEL (WITH TIMER)	DISPLACEMENT	PUMP RATIO	DIAPHRAGM SIZE in. - cm.	CONNECTIONS ALL NPT INPUT / OUTPUT	MAXIMUM DISCHARGE PSI - BAR	OUTPUT PER HOUR GAL. / LTS.
D10-PVC-TR2	.8 cc	1:1	1.0 / 2.5	1/4 - M / 1/4 - F	125 - 8.6	.06 - .63 / .24 - 2.4

**MORGAN PRODUCTS INC.** 28103 Ave. Stanford / Valencia, CA 91355

(661) 257-3022 - (800) 421-8910 - FAX (661) 257-3385

www.morganproducts.com - E-Mail info@morganproducts.com

# MORGAN PRODUCTS

PNEUMATIC CHEMICAL PUMPS FOR THE GAS AND OIL INDUSTRIES

## Parts List Model D10-PVC, D15-PVC, D25-PVC & D40-PVC

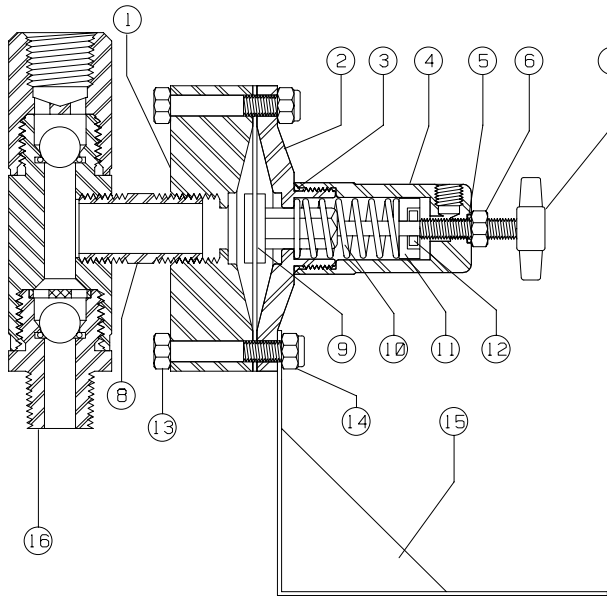

No	Name	D10	D15	D25	D40
1	Pressure Chamber	D10-PVC-1	D15-PVC-1	D25-PVC-1	D40-PVC-1
2	Drive Chamber	D10-2	D15-2	D25-2	D40-2
3	O-Ring Seal	50-21*		100-21*	
4	Spring Housing	D15-3		D25-3	D40-3
5	O-Ring Seal	100-11*			
6	Locknut	50-2			
7	Stroke Adjuster	50-1			
8	Nipple	D15-PVC-11		D25-PVC-11	D40-PVC-11
9	Diaphragm Assembly	D10-7*	D15-7*	D25-7*	D40-7*
10	Return Spring	50-13*		D25-6*	250-13*
11	Spring Retainer	D15-5		D25-5	
12	Retainer Pin	D15-4		D25-4	
13	Chamber Bolt	D15-PVC-10+		D40-PVC-10+	
14	Chamber Locknut	D15-9+		D40-9+	
15	Stand	D10-13	D15-13	D25-13	D40-13
16	Check Valve	D15-PVC-12		D25-PVC-12	D40-PVC-12
	Repair Kit	D10-50	D15-50	D25-50	D40-50

\* = Included in Repair Kit

+ = 6 ea. Required on D10, D15 & D25

8 ea. Required on D40

### Set-Up and Operation

1. Discard all red protective closures.
2. Connect the suction check valve (bottom) to the chemical source.
3. Connect the discharge check valve (top) to your process line.
4. Connect a regulated air/gas supply (150 psi maximum) to the timing relay.
5. Set the air/gas supply 10-15 psi higher than process line pressure.
6. Set cycle rate on the TR2 timing relay to get flow rate required. (see chart)

CAUTION: Do not use this pump with chemicals that become hazardous when aerated.

CAUTION: Check Valves will not stop flow of chemical supply. Install a shut off valve between pump and chemical source.

MODEL NO.	D10-PVC	D15-PVC	D25-PVC	D40-PVC
Volume Per Stroke	.3 oz - .8cc	.2 oz - 6cc	.7oz - 21cc	1.7 oz - 51cc
Maximum Volume Per Day	15 ga. - 58 liters	125 ga. - 473 liters	400 ga. - 1514 liters	720 ga. - 2725 liters
Maximum Stroke Rate	50 SPM			
Maximum Design Pressure	250 PSI		17.24 BAR	
Maximum Operating Pressure	150 PSI		10.34 BAR	
Diaphragm Size	1 in. - 2.5 cm.	1.5 in - 3.8 cm	2.5 in - 6.35 cm	4 in - 10.16 cm
Diaphragm Material	Teflon			
Pump Material	316 SS			
Suction Size	1/4 NPT (M)	1/4 NPT (M)	1/2 NPT (M)	3/4 NPT (M)
Discharge Size	1/4 NPT (F)	1/4 NPT (F)	1/2 NPT (F)	3/4 NPT (F)

**MORGAN PRODUCTS INC.** 28103 Ave. Stanford / Valencia, CA 91355

(661) 257-3022 - (800) 421-8910 - FAX (661) 257-3385