

MORGAN PRODUCTS

PNEUMATIC CHEMICAL PUMPS FOR THE GAS AND OIL INDUSTRIES

SNAP RELAY

AIR ACTUATED SNAP RELAY

MODEL SR1S

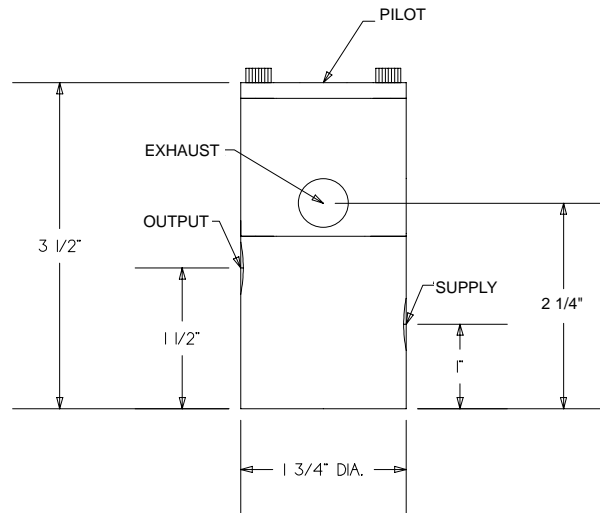

MODEL SR2S

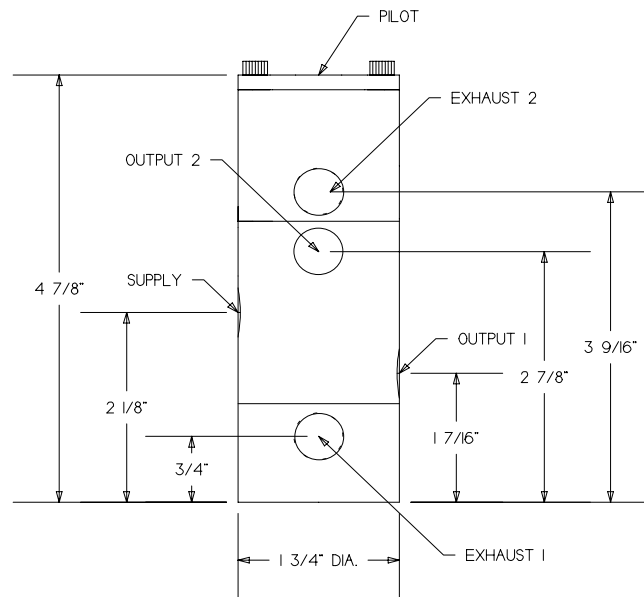

CONNECTIONS
INPUT / OUTPUT / EXHAUST / PILOT

RANGE
SPM

PRESSURE RATING
PSI / BAR

MATERIAL

1/4 NPT-F / 1/4 NPT-F / 1/4 NPT-F / 1/8 NPT-F

0 - 50

25-150 / 1.7-10.3

300 SERIES SS

MORGAN PRODUCTS INC. 28103 Ave. Stanford / Valencia, CA 91355

(661) 257-3022 - (800) 421-8910 - FAX (661) 257-3385 - www.morganproducts.com - E-Mail info@morganproducts.com

MORGAN PRODUCTS

PNEUMATIC CHEMICAL PUMPS FOR THE GAS AND OIL INDUSTRIES

Parts List Model SR1S

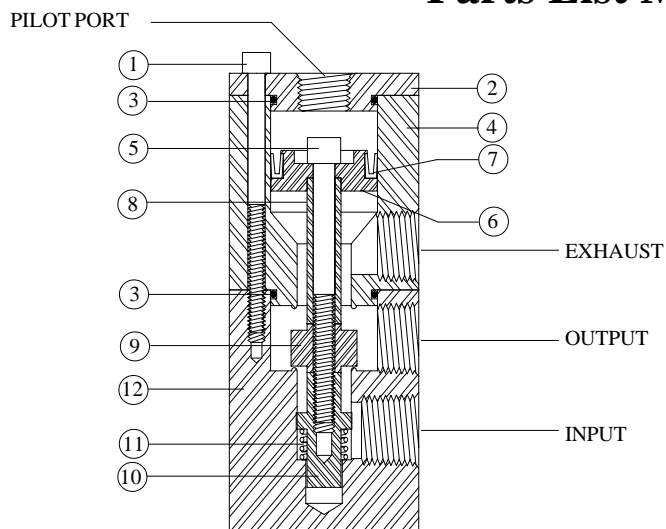

NO	NAME	PART NO.	MATERIAL
1	Cap Screw	SR1S-1 (4)	18-8 SS
2	Cap	SR1S-2	316 SS
3	O-Ring	100-21 (2)*	Buna-N
4	Upper Valve Body	SR1S-4	316 SS
5	Bolt	SR1S-5	18-8 SS
6	Drive Piston	SR1S-6	316 SS
7	Piston Seal	50-9 *	BUNA-N
8	Upper Shaft	SR1S-9	313 SS
9	Valve Seat	SR1S-11 *	Buna-N/Alum.
10	Lower Shaft	SR1S-14	316 SS
11	Spring	SR1S-15 *	302 SS
12	Lower Valve Body	SR1S-16	316 SS
	Repair Kit	SR1S-50	

The SR1S relay is used in series with, and mounted between the timing relay and the pump. When it is desirable to use but one supplyline. The SR1S is also used when two supply lines are more desirable. The SR1S snap acting relay is plumbed directly to the pump with one supply. The timing relay is used to activate the SR1S using a second air supply. On double acting pumps, (Example: Model 5500DS) the SR2S snap acting relay must be used in conjunction with the timing relay, using two separate air supplies. The SR2S snap relay requires a regulated air or gas source separate from that of the timing relay it is used in conjunction with.

Parts List Model SR2S

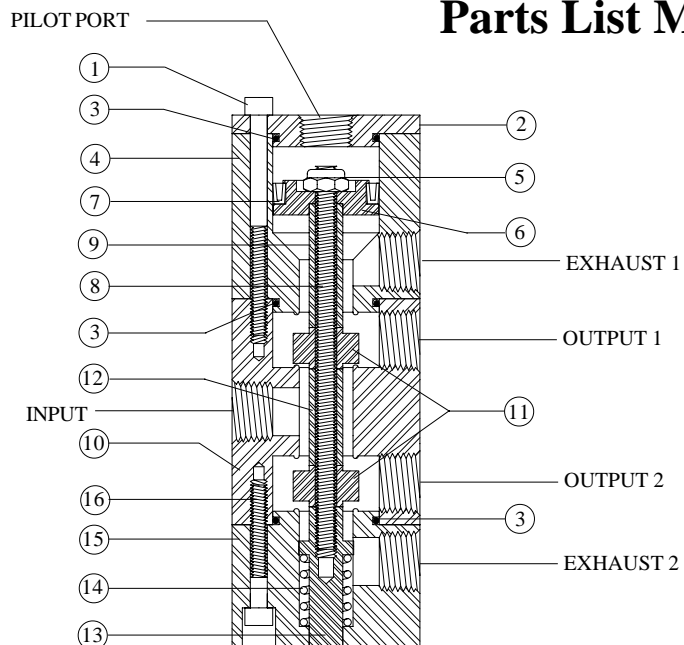

NO	NAME	PART NO.	MATERIAL
1	Cap Screw	SR1S-1 (4)	18-8 SS
2	Cap	SR1S-2	316 SS
3	O-Ring	100-21 (3)*	Buna-N
4	Upper Valve Body	SR1S-4	316 SS
5	Nut	SR2S-5	18-8 SS
6	Drive Piston	SR1S-6	316 SS
7	Piston Seal	50-9 *	BUNA-N
8	Tie Rod	SR2S-8	18-8 SS
9	Upper Shaft	SR1S-9	316 SS
10	Center Valve Body	SR2S-10	316 SS
11	Valve Seat	SR1S-11 (2)*	Buna-N/Alum.
12	Center Shaft	SR2S-12	304 SS
13	Lower Shaft	SR2S-14	316 SS
14	Spring	SR2S-15 *	302 SS
15	Lower Valve Body	SR2S-16	316 SS
16	Cap Screw	SR2S-17 (4)	18-8 SS
	Repair Kit	SR2S-50	

ALL PARTS INCLUDED IN REPAIR KIT ARE NOTED BY: *

MORGAN PRODUCTS INC. 28103 Ave. Stanford / Valencia, CA 91355

(661) 257-3022 - (800) 421-8910 - FAX (661) 257-3385 - www.morganproducts.com - E-Mail info@morganproducts.com