

MORGAN PRODUCTS

PNEUMATIC CHEMICAL PUMPS FOR THE GAS AND OIL INDUSTRIES

MODEL HD562-5K-TR2-SR1S

AIR ACTUATED HYDRAULIC DIAPHRAGM PUMP

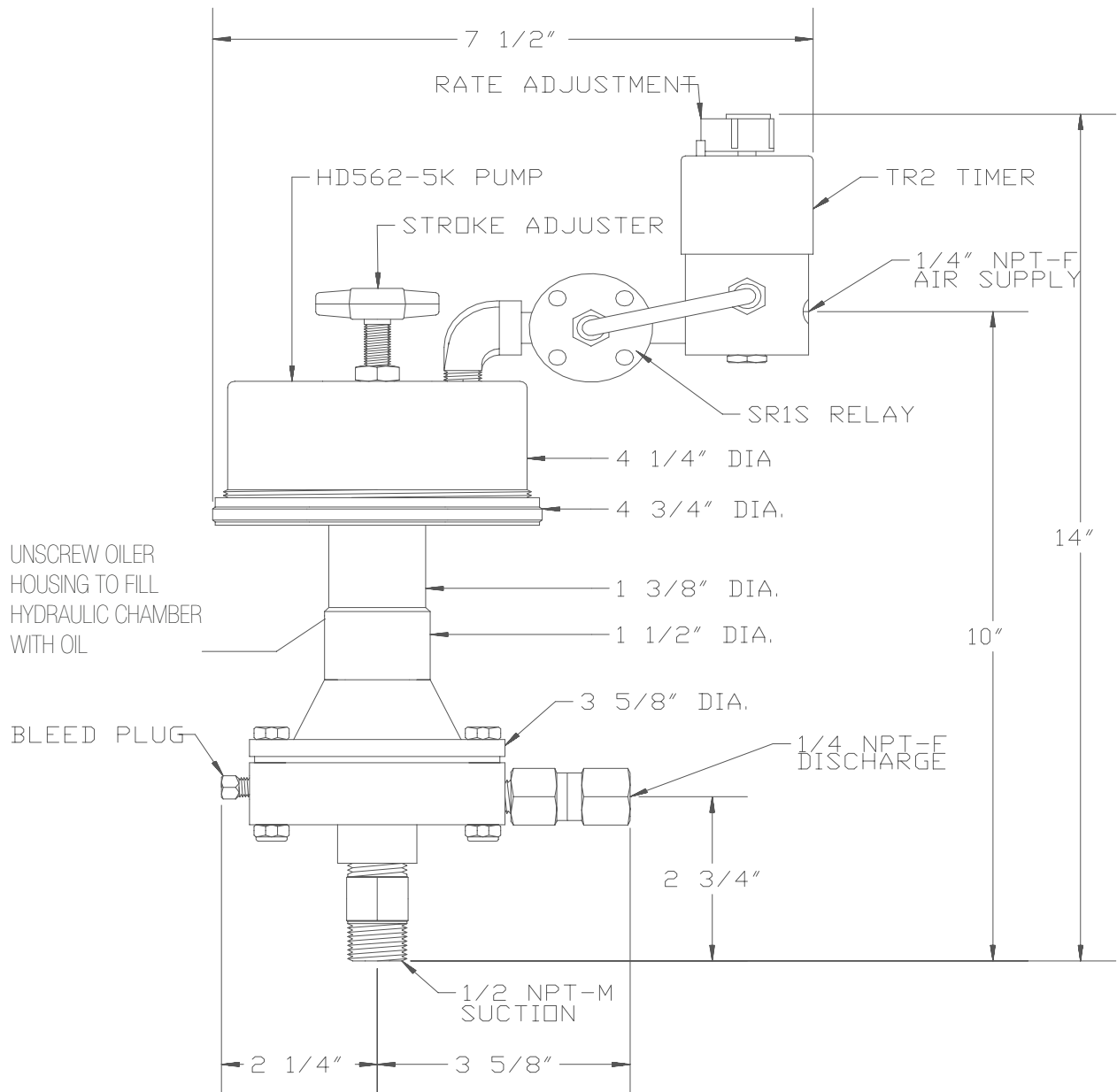

MODEL (WITH TIMER)	DISPLACEMENT	PUMP RATIO	STROKE LENGTH in. - cm.	CONNECTIONS ALL NPT INPUT / OUTPUT	MAXIMUM DISCHARGE PSI - BA	OUTPUT PER HOUR GAL. / LTS.
HD562-5K	3.5 c	50:1	1 - 2.5	1/2 - M / 1/4 - F	5000 - 345	.25 - 2.5 / 1 / 9.5

MORGAN PRODUCTS INC. 28103 Ave. Stanford / Valencia, CA 91355

(661) 257-3022 - (800) 421-8910 - FAX (661) 257-3385

Web www.morganproducts.com - E-Mail info@morganproducts.com

HD562-5K

TR2

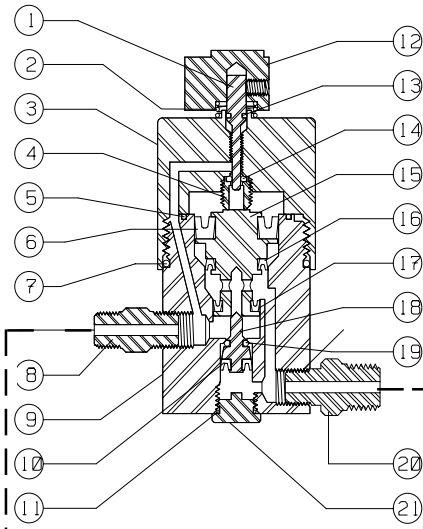
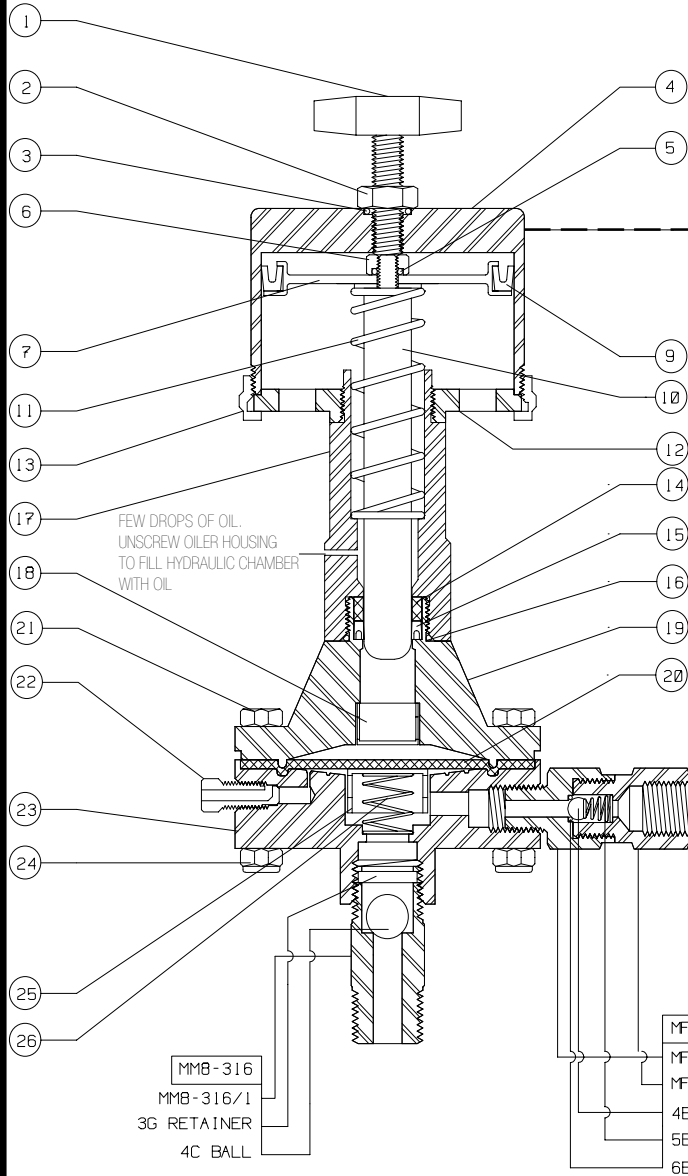

SR1S

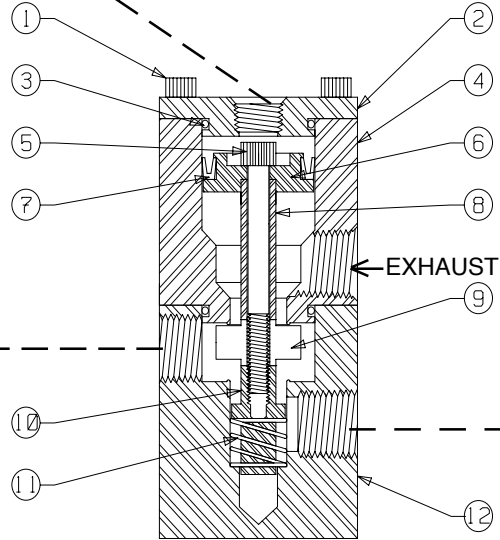

To order check valve parts; use check valve designation & dash number.

EXAMPLE: Ball for MF4-316-2 Order MF4-316-2/4

Keep all rubber goods lubricated with Morgan Products grease or equivalent.

**MODEL HD562-5K
PARTS LIST**

NO	NAME	PART NO.
1	Stroke Adjuster	HD312-1
2	Lock Nut	100-2
3	O-Ring Seal	100-3 *
4	Air Chamber	400-4
5	O-Ring Seal	100-11 *
6	Piston Locknut	100-7
7	Piston	400-8
9	Piston Seals	400-9 *
10	Plunger	HD562-15 *
11	Return Spring	HD562-13 *
12	Faceplate	HD562-5K-6
13	Air Chamber Ring	400-5
14	Back Up Ring	HD562-19 * +
15	Pressure Seal	HD562-20 * +
16	O-Ring Seal	100-21 *
17	Oiler Housings	HD562-14
18	Spring Cup	HD312-35
19	Hydraulic Chamber	HD562-29
20	Diaphragm	HD562-32 *
21	Chamber Bolt	HD-5K-36 (8)
22	Bleeder	125-22
23	Pressure Chamber	HD562-23
24	Locknut	HD-5K-37 (8)
25	Spring Cup	HD562-35
26	Diaphragm Spring	HD312-36 *
	1oz. Grease	*
	1oz. Oil	HD187-24 *

* = Included in Repair Kit

+ = Included in Seal Set

MATERIAL SPECIFICATIONS

NAME	STANDARD	OPTION
Piston Seals	Buna - N	Viton
Plunger	17-4 SS	
Return Spring	Teflon Coated Inconel	
Back Up Ring	PVC	
Pressure Seal	Graphite Filled Teflon	
Diaphragm	Teflon Faced Buna-N	
Chamber Bolt	18-8 SS	
Bleeder	316 SS	
Pressure Chamber	316 SS	
Spring Cup	316 SS	
Diaphragm Spring	Inconel	
Check Valve Bodies	316 SS	
Check Valve Seals	Teflon	
Check Valve Balls	Ceramic	
Check Valve Springs	Inconel	
All Other Parts	303 or 304 SS	

**MODEL TR2
PARTS LIST**

NO	NAME	PART NO.	MATERIAL
1	Metering Valve	TR2-3	303 SS
2	Knob Spring	TR2-2	302 SS
3	Upper Body	TR2-5	303 SS
4	Metering Seat	TR2-6	18-8 SS
5	O-Ring	TR2-13 *	BUNA-N
6	Upper Seal	TR2-10 *	VITON
7	O-Ring	TR2-14 *	BUNA-N
8	1/8" NPT Nipple	TR2-22	303 SS
9	Lower Body	TR2-8	303 SS
10	Poppet Seal	TR2-17 *	VITON
11	Plug Seal	TR2-18 *	BUNA-N
12	Knob	TR2-1	PLASTIC
13	O-Ring	TR2-4 *	BUNA-N
14	Teflon Seal	TR2-7 *	TEFLON
15	Piston	TR2-9	NYLON
16	Middle Seal	TR2-11 *	VITON
17	Lower Seal	TR2-12 *	VITON
18	Poppet	TR2-15	PVC
19	Poppet O-Ring	TR2-16 *	VITON
20	1/8 x 1/4 NPT Nipple	TR2-21	303 SS
21	Plug	TR2-19	303 SS
	1oz. Grease	*	

* = Included in Repair Kit

**MODEL SR1S
PARTS LIST**

NO	NAME	PART NO.	MATERIAL
1	Cap Screw	SR1S-1 (4)	18-8 SS
2	Cap	SR1S-2	303 SS
3	O-Ring	SR1S-3 (2)*	Buna-N
4	Upper Valve Body	SR1S-4	303-SS
5	Bolt	SR1S-5	18-8 SS
6	Drive Piston	SR1S-6	303 SS
7	Piston Seal	SR1S-7 *	Buna-N
8	Upper Shaft	SR1S-9	304 SS
9	Valve Seat	SR1S-11*	Buna-N & Alum.
10	Lower Shaft	SR1S-14	303 SS
11	Spring	SR1S-15*	302 SS
12	Lower Valve Body	SR1S-16	303 SS

* = Included in Repair Kit

REPAIR KITS AND SEAL SET

PART NO.	DESCRIPTION	MODEL
HD562-5K-50	REPAIR KIT	HD562-5K
HD562-48	SEAL SET	ALL
TR2-50	REPAIR KIT	TR2
SR1S-50	REPAIR KIT	SR1S

**AIR / GAS USAGE
SCF/DAY AT 1 STROKE PER MINUTE**

MODEL	25 psi	50 psi	75 psi	100 psi	125psi	150 psi
HD562-5K	28.0	45.5	63.0	80.5	98.0	115.5

Table constant multiplied by stroke rate = SCFD
 Example: HD562-5K (operated at 50 psi) Multiply 45.5 by 20 SPM = 910 SCFD

INSTALLATION INSTRUCTIONS

1. Discard all red plastic closures.
2. Connect suction check valve, to a gravity fed chemical source.
3. Connect discharge check valve, to process line.
4. Connect a regulated air or gas supply, to the timing relay.
5. Fill pump with oil provided, oil will flow out of the bleed hole to regulate oil level.
 ** This must be done BEFORE start up.**
6. Open bleeder valve until chemical flows from bleeder.
7. Set regulator at 10 to 15 psi ABOVE the pressure required.
 (See Discharge pressure graph.)
8. Set cycle rate for approximate strokes per minute.
 (See volume graph)

CAUTION: Use only light hydraulic oil.

VOLUME

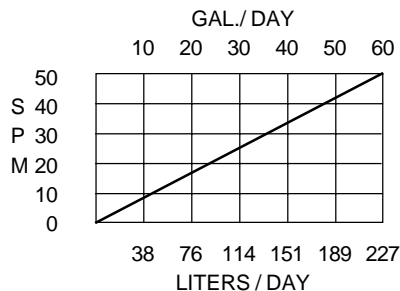

DISCHARGE PRESSURE

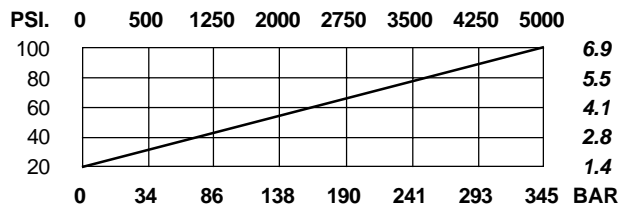

MORGAN PRODUCTS INC. 28103 Ave. Stanford / Valencia, CA 91355

(661) 257-3022 - (800) 421-8910 - FAX (661) 257-3385

Web www.morganproducts.com - E-Mail info@morganproducts.com