

MORGAN PRODUCTS

PNEUMATIC CHEMICAL PUMPS FOR THE GAS AND OIL INDUSTRIES

MODEL HD1062-TR2-SR1S / HD1062-3K-SR1S-TR2

AIR ACTUATED HYDRAULIC DIAPHRAGM PUMP

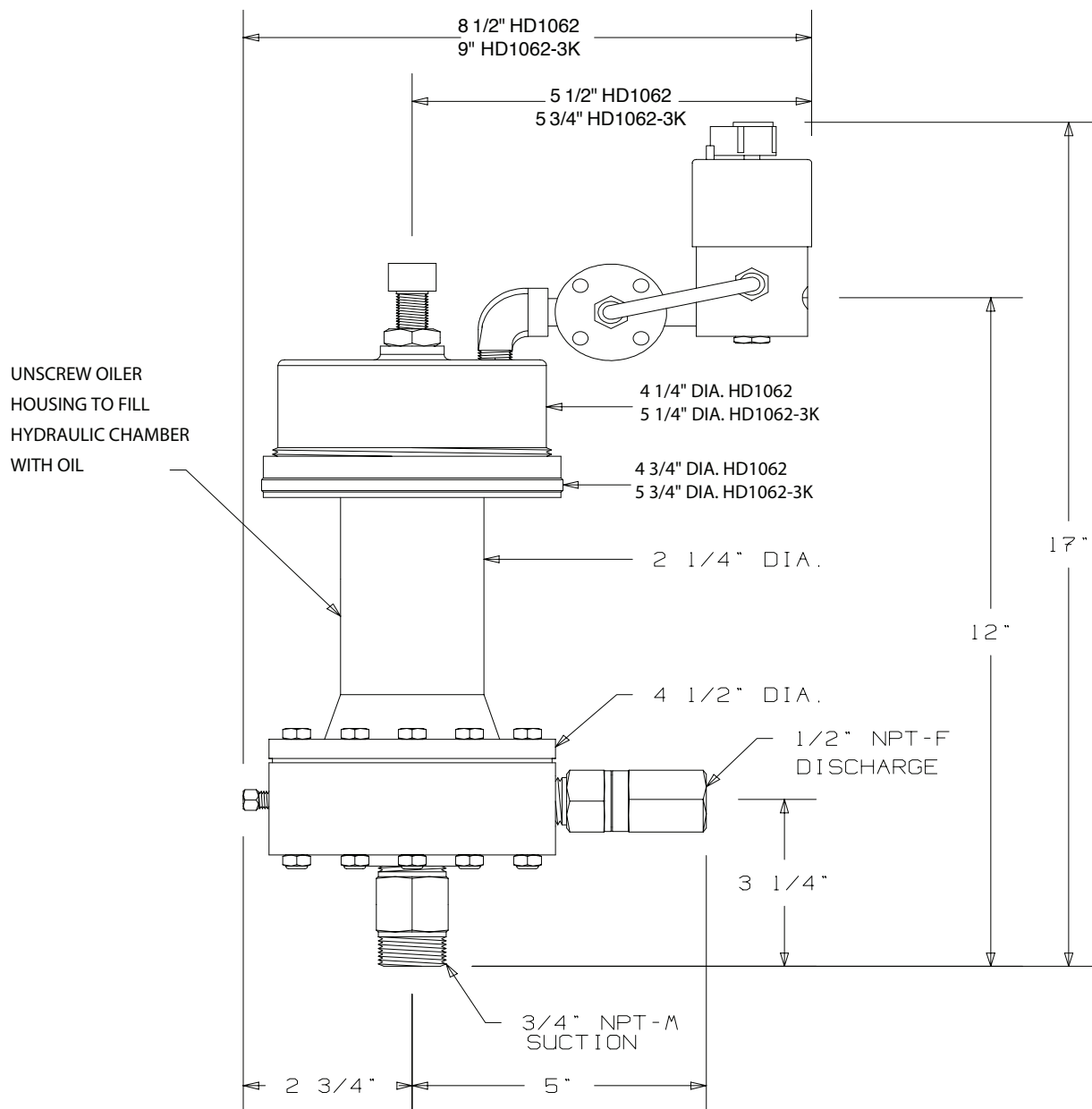

MODEL	PUMP	STROKE	CONNECTIONS	MAXIMUM	OUTPUT	
(WITH TIMER)	DISPLACEMENT	LENGTH	ALL NPT	DISCHARGE	PER HOUR	
		in. - cm.	INPUT / OUTPUT	PSI - BAR	GAL. / LTS.	
HD1062-TR2-SR1S	12.8 cc	10:1	1 - 2.54	3/4 - M / 1/2 - F	1000 - 68.9	1 - 10.4 / 3.9 - 39
HD1062-3K-TR2-SR1S	12.8 cc	20:1	1 - 2.54	3/4 - M / 1/2 - F	3000 - 206.8	1 - 10.4 / 3.9 - 39

MORGAN PRODUCTS INC. 28103 Ave. Stanford / Valencia, CA 91355

(661) 257-3022 - (800) 421-8910 - FAX (661) 257-3385

www.morganproducts.com - E-Mail info@morganproducts.com

MORGAN PRODUCTS

PNEUMATIC CHEMICAL PUMPS FOR THE GAS AND OIL INDUSTRIES

Parts List Model HD1062

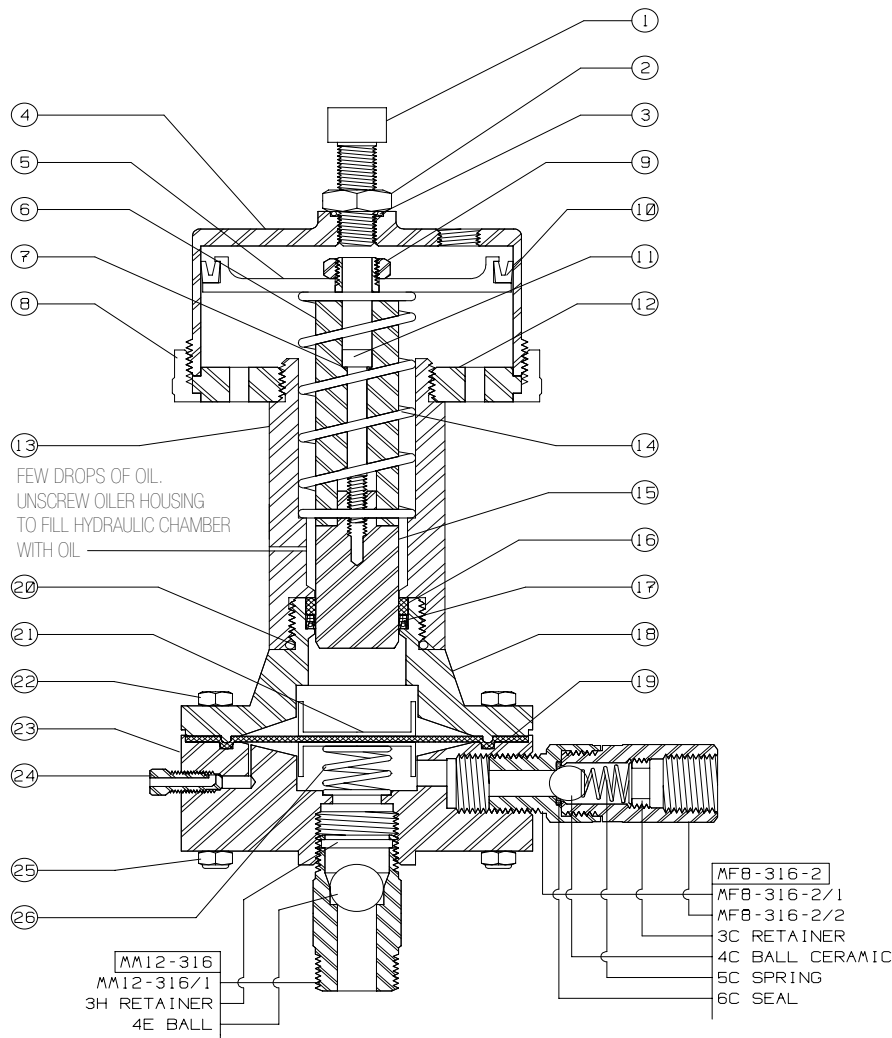

NO	NAME	PART NO.
1	Stroke Adjuster	3000-1
2	Locknut	3000-2
3	O-Ring Seal	3000-3 *
4	Air Chamber	4000-4
5	Piston	4000-8
6	Plunger Guide	HD1062-10
7	O-Ring Seal	100-11 *
8	Air Chamber Ring	4000-5
9	Piston Locknut	3000-7
10	Piston Seal	400-9 *
11	Plunger Bolt	3000-26
12	Faceplate	4000-6
13	Oiler Housing	HD1062-14
14	Return Spring	3000-13 *
15	Plunger	HD1062-15*
16	Back-up Ring	HD1062-19*
17	Pressure Seal	HD1062-20*
18	Hydraulic Chamber	HD1062-29
19	Diaphragm	HD1062-32*
20	Body O-Ring Seal	3000-21 *
21	Spring Cup	HD1062-35(2)
22	Chamber Bolt	HD1062-30(10)
23	Fluid Chamber	HD1062-23
24	Bleeder	125-22
25	Locknut	D40-9 (10)
26	Diaphragm Spring	HD1062-36*
N/S	4 oz. Oil	HD1062-24*
N/S	Elbow	3000-27
N/S	1oz. Grease	*
N/S	1/4-20 Cap Screw	4000-28
N/S	1/4 Washer	4000-29
	Repair Kit	HD1062-50
	Seal Set	HD1062-48

* = Included in Repair Kit

INSTALLATION INSTRUCTIONS

1. Discard all red plastic closures.
2. Connect suction check valve, to a gravity fed chemical source.
3. Connect discharge check valve, to process line.
4. Connect a regulated air or gas supply, to the timing relay.
5. Fill oil reservoir with oil provided, until oil flows out of bleed hole.** This must be done BEFORE start up.**
6. Open bleeder valve until chemical flows from bleeder.
7. Set regulator at 10 to 15 psi ABOVE the pressure required.
(See Discharge pressure graph.)
8. Set cycle rate in strokes per minute.
(See volume graph)

CAUTION: Use only light hydraulic oil.

DISCHARGE PRESSURE

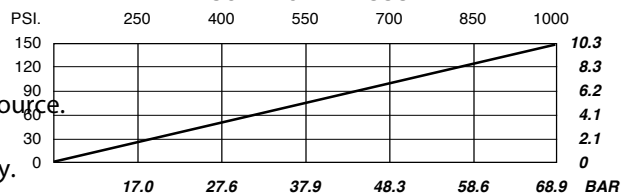

VOLUME

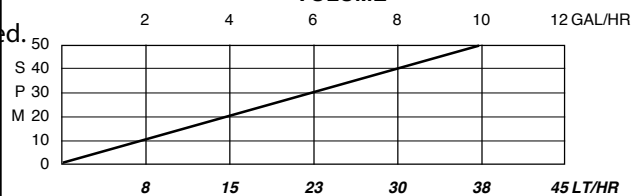

MORGAN PRODUCTS INC. 28103 Ave. Stanford / Valencia, CA 91355

(661) 257-3022 - (800) 421-8910 - FAX (661) 257-3385

MORGAN PRODUCTS

PNEUMATIC CHEMICAL PUMPS FOR THE GAS AND OIL INDUSTRIES

Parts List Model HD1062-3K

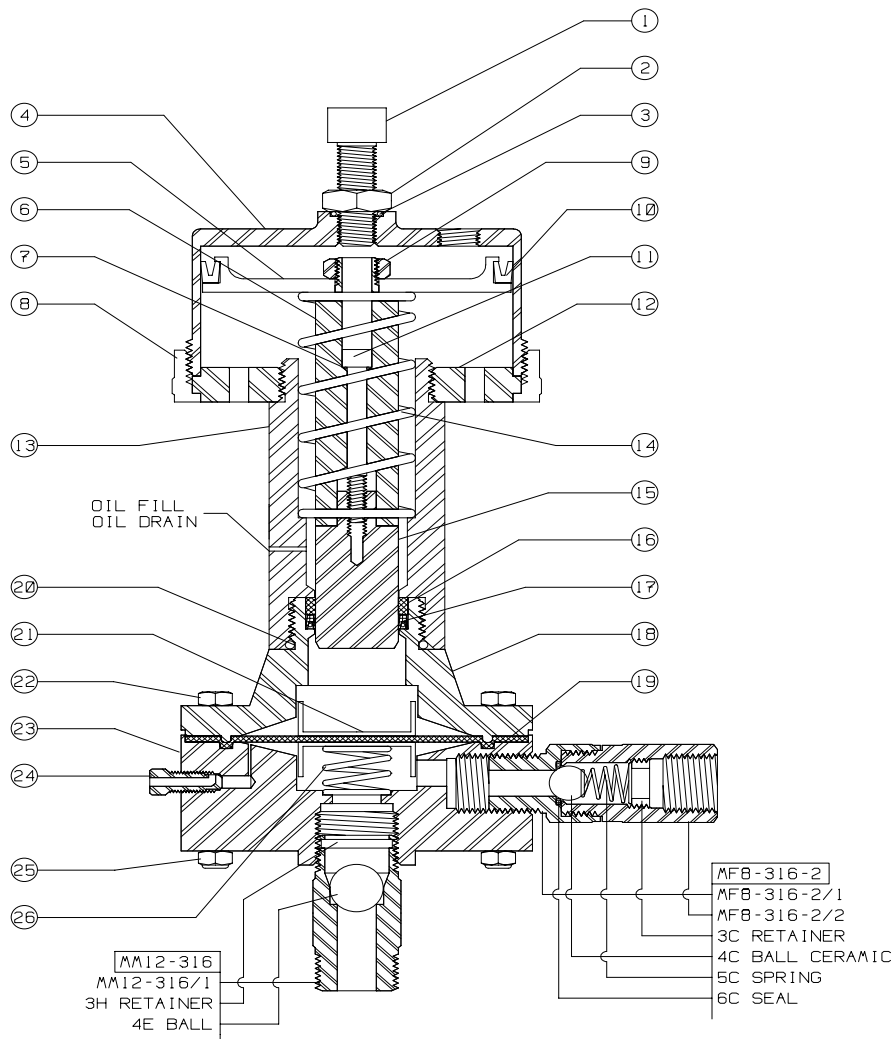

NO	NAME	PART NO.
1	Stroke Adjuster	3000-1
2	Locknut	3000-2
3	O-Ring Seal	3000-3 *
4	Air Chamber	HD1062-3K-4
5	Piston	HD1062-3K-8
6	Plunger Guide	HD1062-10
7	O-Ring Seal	100-11 *
8	Air Chamber Ring	HD1062-3K-5
9	Piston Locknut	3000-7
10	Piston Seal	HD1062-3K-9*
11	Plunger Bolt	3000-26
12	Faceplate	HD1062-3K-6
13	Oiler Housing	HD1062-14
14	Return Spring	3000-13 *
15	Plunger	HD1062-15*
16	Back Up Ring	HD1062-19*
17	Pressure Seal	HD1062-20*
18	Hydraulic Chamber	HD1062-29
19	Diaphragm	HD1062-32*
20	O-Ring Seal	3000-21 *
21	Spring Cup	HD1062-35(2)
22	Chamber Bolt	HD1062-30(10)
23	Fluid Chamber	HD1062-23
24	Bleeder	125-22
25	Locknut	D40-9 (10)
26	Diaphragm Spring	HD1062-36*
N/S	4 oz. Oil	HD1062-24*
N/S	Elbow	3000-27
N/S	1oz. Grease	*
N/S	1/4-20 Cap Screw	4000-28
N/S	1/4 Washer	4000-29
	Repair Kit	HD1062-3K-50
	Seal Set	HD1062-48

* = Included in Repair Kit

INSTALLATION INSTRUCTIONS

1. Discard all red plastic closures.
2. Connect suction check valve, to a gravity fed chemical source.
3. Connect discharge check valve, to process line.
4. Connect a regulated air or gas supply, to the timing relay.
5. Fill oil reservoir with oil provided, until oil flows out of bleed hole.** This must be done BEFORE start up.**
6. Open bleeder valve until chemical flows from bleeder.
7. Set regulator at 10 to 15 psi ABOVE the pressure required. (See Discharge pressure graph.)
8. Set cycle rate in strokes per minute. (See volume graph)

CAUTION: Use only light hydraulic oil.

DISCHARGE PRESSURE

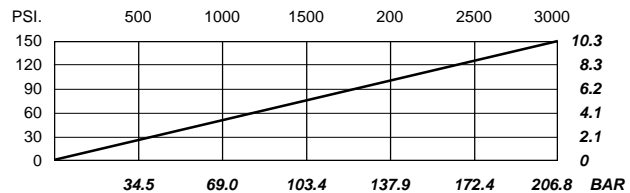

VOLUME

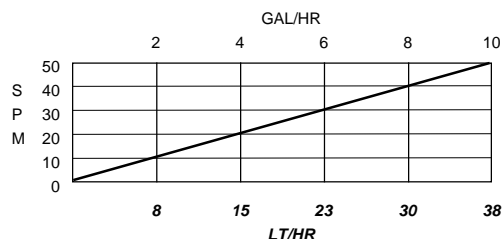

MORGAN PRODUCTS INC. 28103 Ave. Stanford / Valencia, CA 91355

(661) 257-3022 - (800) 421-8910 - FAX (661) 257-3385